



### Description

The Uni-Imp Series of ultra fast surge protectors, protects sensitive components against overvoltages without regard to rate of voltage rise. The voltage at which the Uni-Imp trips does not vary by more than  $\pm 10$  percent from slow DC overvoltages to 200kV/ $\mu$ s transients. When subjected to rapidly rising voltages (5kV/ $\mu$ s or more) a tolerance of  $\pm 20$  percent must be applied. Any trip voltage is available from 550V to 20kV.

### Lifetime

The lifetime of the Uni-Imp can be approximated in terms of the cumulative charge, in coulombs (Q) that can be passed through the device without changing its trip voltage by more than 20 percent. Expressing the height of a current pulse in amperes and its duration in seconds, the area under the pulse is the coulomb of charge contained in it.

### Example 1:

A 2.0kV Uni-Imp is required to pass a 3,000 peak amp pulse having a 10 $\mu$ s half-width. Approximating the pulse shape by a triangle, the charge contained in the pulse is:

$$q = 3,000 \text{ amps} \times 10^{-5} \text{ sec} = 0.03 \text{ coulombs}$$

The life curve shows that a 2.0kV unit has a Q = 110 coulomb capability. Thus, its life under these conditions is approximately:

$$\text{Life} = Q/q = 110/0.03 = 3,667 \text{ discharges}$$

### Example 2:

A 10kV Uni-Imp when tripped by a transient overvoltage must dump a 1.5 $\mu$ F capacitor charged to 9kV. The charge stored in the capacitor is:

$$q = CV = 1.5 \times 10^{-6} \text{ farads} \times 9,000 \text{ Volts} = 13.5 \times 10^{-3}$$

In this case, the life curve shows the cumulative charge capability is Q = 65 coulombs and the approximate lifetime of the Uni-Imp will be:

$$\text{Life} = Q/q = (65/13.5) \times 10^3 = 4,800 \text{ discharges}$$

### Reaction Time

The Uni-Imp can be considered to have zero reaction time over the range of transient speeds encountered in almost any application. For very special situations, such as EMP protection, it is of interest to know the ultimate limit of the transition time required for the Uni-Imp to go from the open circuit condition to the start of conduction.

Tests were made at two independent laboratories with sub nanosecond rise-time pulse generators at 4000kV/ $\mu$ s and 5600kV/ $\mu$ s. The results showed the limiting transition time to be two nanoseconds from the time the pulse is applied, regardless of the particular trip voltage of the Uni-Imp tested (0.55, 2.0, 4.0, 6.0, and 8.0kV.)

Thus, if the transient is sufficiently fast that the trip voltage is reached in less than 2ns, the Uni-Imp will allow the voltage to overshoot. The limiting ramp speed for zero overshoot as a function of the trip voltage is given by:

$$S_L = V_T / (2.0 \times 10^{-3}) \text{ kV}/\mu\text{s}$$

where  $V_T$  is the trip voltage, in kV. For transients faster than this, the voltage overshoot is given by:

$$\Delta V = (2.0 \times 10^{-3}) S - V_T$$

where S is the pulse rise-time in kV/ $\mu$ s

**Table 1:**  
**Environmental Testing**

All units meet the requirements of MIL-STD 202 as outlined below		
Parameter	Test Specifications	Test Conditions
Vibration	204B	C
Shock	213A	A except 100 g's
	213A	C
	213A	C except 1ms
Humidity	103B	B
Temperature Cycling	102A	C
Barometric Pressure	105C	B
Thermal Shock	107	B

**Table 2:**  
**Ratings & Characteristics**

Series	Trip Voltage (kV) See Notes	Capacitance (pF)
UBD	.55	<20
	.60	<20
	.65	<20
	.75	<20
	.85	<20
	1.00	<15
	1.20	<15
	1.50	<15
	2.00	<10
	2.50	<10
	3.00	<5
UBT & UGT	4.00	<5
	5.00	<3
	6.00	<3
	7.50	<2
	10.00	<2
	12.00	<2
	15.00	<2
	20.00	<2

**Notes:**

Operating temperature range: -65°C to +85°C.

Insulation Resistance: 10,000MΩ for UBD, UBT and UGT Series.

Resistance measured at 100Vdc.

The maximum pulse and minimum DC breakdowns, over the lifetime of the arrester, are defined in terms of the trip voltage,  $V_T$ :

$$\text{Maximum Pulse Breakdown} = V_T + 20 \text{ percent}$$

$$\text{Minimum DC Breakdown} = V_T - 20 \text{ percent}$$

### Uni-Imp Lifetime

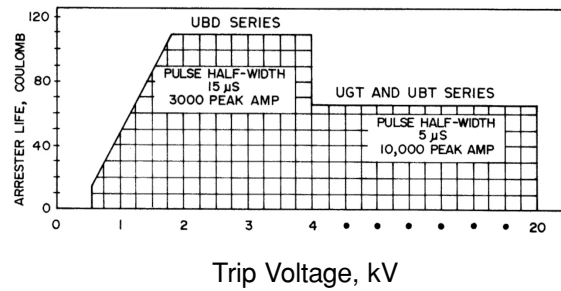

### Uni-Imp Applications

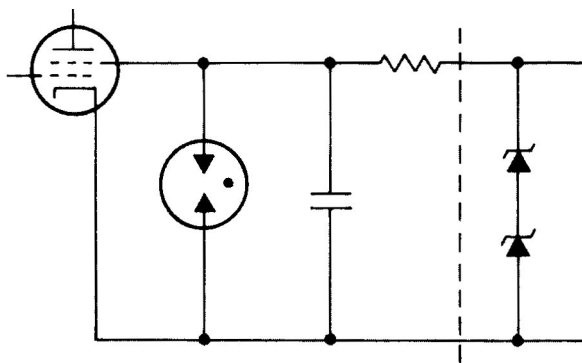

Protection for Solid State Power Supplies

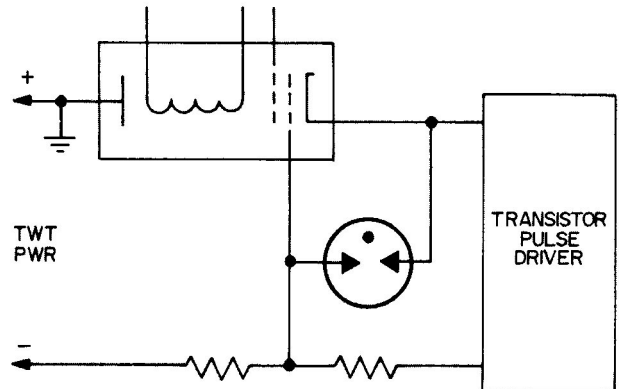

TWT Protection

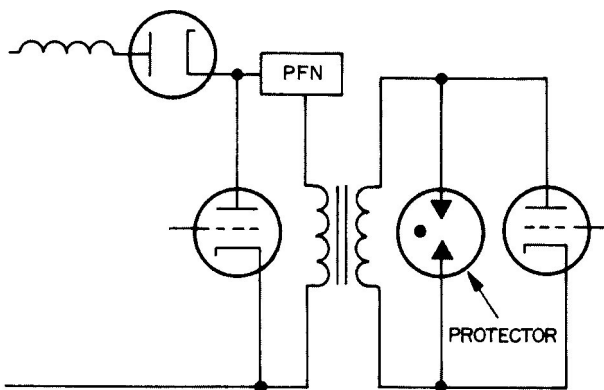

Magnetron Pulse Transformer Protection

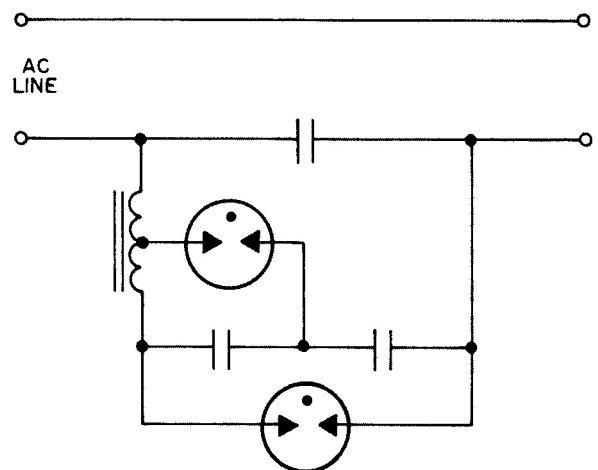

Protecting Phase Correction Capacitors

## Contact Information:

High Energy Devices, LLC  
26 Hollenberg Court  
Bridgeton, MO 63044  
Phone: 314.291.0030  
Fax: 314.291.8184  
E-mail: [info@highenergydevices.com](mailto:info@highenergydevices.com)  
[www.highenergydevices.com](http://www.highenergydevices.com)

---

HIGH ENERGY DEVICES, LLC MAKES NO REPRESENTATIONS OR WARRANTIES WITH RESPECT TO THE ACCURACY OR COMPLETENESS OF THE CONTENTS OF THIS PUBLICATION AND RESERVES THE RIGHT TO MAKE CHANGES TO SPECIFICATIONS AND PRODUCT DESCRIPTIONS AT ANY TIME WITHOUT NOTICE. NEITHER CIRCUIT PATENT LICENSES NOR INDEMNITY ARE EXPRESSED OR IMPLIED. EXCEPT AS SET FORTH IN HIGH ENERGY DEVICES' STANDARD TERMS AND CONDITIONS OF SALE, HIGH ENERGY DEVICES, LLC ASSUMES NO LIABILITY WHATSOEVER, AND DISCLAIMS ANY EXPRESS OR IMPLIED WARRANTY, RELATING TO ITS PRODUCTS INCLUDING, BUT NOT LIMITED TO, THE IMPLIED WARRANTY OF MERCHANTABILITY, FITNESS FOR A PARTICULAR PURPOSE, OR INFRINGEMENT OF ANY INTELLECTUAL PROPERTY RIGHT.

THE PRODUCTS DESCRIBED IN THIS DOCUMENT ARE NOT DESIGNED, INTENDED, AUTHORIZED OR WARRANTED FOR USE AS COMPONENTS IN SYSTEMS INTENDED FOR SURGICAL IMPLANT INTO THE BODY, OR IN OTHER APPLICATIONS INTENDED TO SUPPORT OR SUSTAIN LIFE, OR WHERE MALFUNCTION OF HIGH ENERGY DEVICES' PRODUCT MAY RESULT IN DIRECT PHYSICAL HARM, INJURY, OR DEATH TO A PERSON OR SEVERE PROPERTY OR ENVIRONMENTAL DAMAGE. HIGH ENERGY DEVICES, LLC RESERVES THE RIGHT TO DISCONTINUE OR MAKE CHANGES TO ITS PRODUCTS AT ANY TIME WITHOUT NOTICE.

---

Specification: AN-UI-10  
©Copyright 2002, High Energy Devices, LLC  
All rights reserved. Printed in USA  
March 2008.