

Features

- Excess noise ratios (ENR): up to 20dB
- Broad bandwidth
- Excellent long term stability
- Life up to 20,000 hours
- AC, DC, or pulsed operation

Applications

- Noise figure measurement

Description

High Energy Devices' TD Series of gas discharge microwave noise tubes and TN Series of gas discharge microwave noise sources are the element in a microwave RF system that allows accurate measurements of the noise figure of the receiver or its components. The requirements of a device used for making such noise figure measurements include broad bandwidth inherent in the active element, stability, ease of operation, and long life. In general, the range of usefulness of these noise sources permits measurements of noise figures from about 2 to 30dB. The PS237 through PS240 current-regulated power supplies can be used to operate many of the noise sources described herein.

Specification Ranges

Parameter	Range	Units
Frequency	0.2 - 220.0	GHz
ENR	8.8 - 20.1	dB
Operating Current	30 - 250	mA
Starting Voltage	0.9 - 7.0	kV

Contact High Energy Devices for TD and TN part numbers or other requirements not listed.

Ordering Information

A complete part number is represented by the information in the Part Number column of the specification table.

TD Series Gas Discharge Noise Source Tubes with Filamentary or Hollow Cathodes
Specifications (@25°C)

Frequency Range (GHz)	Band	Wave Guide	Part Number/ EIA Type Number	Package Outline	Mount Type	Recommended Mode of Operation ⁽¹⁾	Minimum Starting Voltage Spike (kV)	DC Anode Starting Current (mA)	Tube Drop (Vdc)	Tube-In Mount ENR (dB)
1.12-1.70 (1.20-1.40 only)	L	WR-650	TD21/6881	1	90°H	DC	4.0	250	65	15.20 ⁽²⁾
			TD29/7101	1a	90°H	AC,DC	4.5	250	130	18.00 ⁽²⁾
			TD33/7147	1a	90°H	AC,DC	4.0	250	75	15.20 ⁽²⁾
			TD49	1	90°H	pulse	4.0	200	125	15.20 ⁽²⁾
			TD62/7992	1	90°H	DC	4.5	250	~145	18.00 ⁽²⁾
			TD75	1	90°H	pulse	4.5	200	235	18.00 ⁽²⁾
			TD91	special	10°E	DC	7.0	250	230	15.20 ⁽²⁾
2.60-3.95	S	WR-284	TD12/6358	2	10°E	DC	2.7	250	80	15.20
			TD22/6782	special	90°H	AC,DC	2.0	250	45	8.85
			TD31	2a	10°E	AC,DC	2.7	250	90	15.20
			TD32	2a	10°E	AC,DC	2.7	250	170	17.80
			TD34/7148	2	10°E	DC	2.7	250	160	17.75
			TD38/8151	2	10°E	pulse	3.3	200	145	15.27
			TD56/8286	2	10°E	pulse	3.5	200	265	17.90
			TD82	special	90°E	DC	0.9	75	55	18.50
3.30-4.90	S	WR-229	TD24	special	10°E	AC,DC	2.5	250	60	15.30
			TD30	special	10°E	AC,DC	2.5	250	110	17.80
3.95-5.85	C(G)	WR-187	TD10/6356	3	10°E	DC	3.1	250	70	15.32
			TD39/7999	3	10°E	pulse	3.5	175	140	15.50
			TD43/8287	3	10°E	pulse	3.5	175	210	17.85
			TD48/7989	3	10°E	DC	2.7	250	135	17.70
			TD83	special	90°E	DC	0.9	100	55	18.90
5.85-8.20	X(J)	WR-137	TD10/6356	3	10°E	DC	3.1	250	75	15.65
			TD39/7999	3	10°E	pulse	3.5	175	140	15.50
			TD43/8287	3	10°E	pulse	3.5	175	210	17.90
			TD48/7989	3	10°E	DC	2.7	250	135	17.75
			TD67/8288	3	15°E	pulse	3.5	150	225	18.00
8.20-12.40	X	WR-90	TD11/6357	4	10°E	DC	2.7	200	75	15.60
			TD23/6882	4	10°E	DC	2.7	200	115	18.00
			TD40/8152	4	10°E	pulse	3.3	175	125	15.60
			TD44/7988	4	10°E	pulse	3.5	175	205	18.00
			TD58/8293	4	10°E	pulse	3.5	175	208	17.75
			TD72/8059	4	10°E	pulse	3.3	175	133	15.56
			TD73	special	90°E	DC	0.9	100	54	14.50
			TD93B	special	90°E	pulse	0.9	100	165	14.50
			TD114	special	10°E	DC	1.5	200	90	15.30
12.40-18.00	Ku	WR-62	TD18/6684	5	10°E	DC	2.7	200	70	15.80
			TD41/8030	5	10°E	pulse	3.3	175	130	15.85
			TD46	special	20°E	AC,DC	~1.2	100	35	15.20 ⁽²⁾
			TD54/7991	5	10°E	DC	2.7	200	130	18.00
			TD55/8290	5	10°E	pulse	3.5	175	230	17.85
			TD92	5	10°E	pulse	3.5	175	125	15.65
18.00-26.50	K	WR-42	TD13/6359	6	10°E	DC	2.7	200	68	15.90
			TD42/8031	6	10°E	pulse	3.3	175	125	16.00
			TD50/7990	6	10°E	DC	2.7	200	157	18.05
			TD51/8291	6	10°E	pulse	3.5	175	260	17.90
			TD81	special	10°E	pulse	3.3	150	148	16.15
26.50-40.00	Ka	WR-28	TD76/7993	special	10°E	DC	2.7	125	130	16.00
			TD77/8292	special	10°E	pulse	3.0	100	175	16.00

⁽¹⁾ DC operation - cathode at one end only. AC, DC operation - cathodes at both end. Pulse operation - cathode at one end specially designed for pulse operation. If the anode current during the "on" tie of a square wavepulse (>100µ duration) is nominally the same as the rated DC anode current, the tube drop during this period will be approximately the same as the rated DC tube drop.

⁽²⁾ Excess noise ratio of tube only.

TD Series Gas Discharge Noise Source Tubes with Indirectly-Heated Cathodes

Specifications (@25°C)

Frequency Range (GHZ)	Band	Part Number/ EIA Type Number	Minimum Starting Voltage Spike (kV)	DC Anode Current (mA)	Tube Drop (Vdc)	Tube-In-Mount ENR (dB)	Used In Mount
3.4-3.6	S	TD124	0.60	75	40	18.30	TN65
2.9-3.1	S	TD129	0.45	75	35	18.50	TN71
2.7-2.9	S	TD121	0.45	75	35	18.50	TN72
8.2-12.4	X	TD126	1.50	100	90	15.60	TN130

MECHANICAL DIMENSIONS mm/(inches)

Noise Source Tubes with Filamentary or Hollow Cathodes

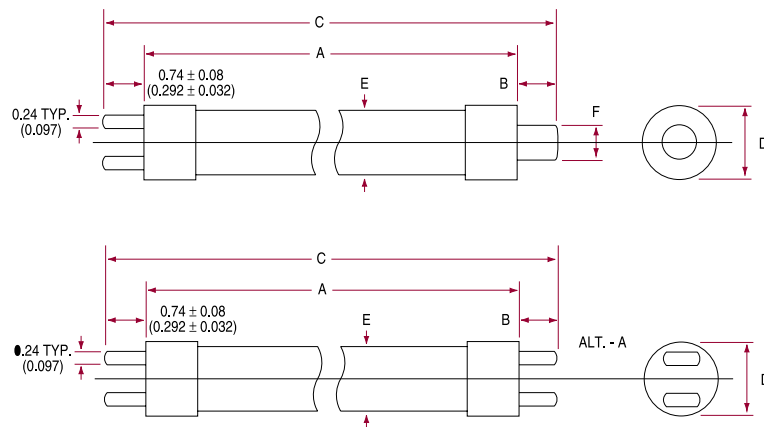

DIMENSIONS (Inches)						
Outline Number	A	B	C	D	E	F
1/1a ⁽³⁾	various	0.500 max	14.625-15.000	1.350-1.435	1.475-1.550	0.188 max
2/2a ⁽³⁾	16.937-17.437	0.310-0.360	17.625-18.000	0.990 max	0.975-1.050	0.305-0.325
3/3a ⁽³⁾	13.875-14.375	0.270-0.320	14.375-15.000	0.555 max	0.547-0.579	0.245-0.265

⁽³⁾ The "a" suffix indicates using the bi-pin termination depicted in the inset labelled "ALT.-A".

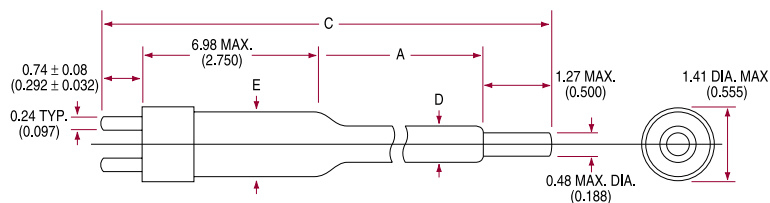

DIMENSIONS (Inches)				
Outline Number	A	C	D	E
4	8.625 min	11.937-12.250	0.370-0.380	0.550 max
5	7.375 min	10.875-11.250	0.235-0.265	0.500 max
6	6.187 min	9.687-10.000	0.160-0.194	0.500 max

TN Series Gas Discharge Noise Source Tubes with Indirectly-Heated Cathodes⁽⁵⁾

Specifications (@25°C)

Band	Part Number	Frequency Range (GHz)	ENR (dB)	Tube Drop (Vdc)	DC Anode Current (mA)	Minimum Starting Voltage Spike (kV)	Circuit Length (Inches)	Mounting	Circuit
VHF	TN46	0.20-0.25	18.5	200	30	1.50	15.50	Helical Coupling	7/8" coax
UHF	TN47	0.56-0.64	20.3	325	50	2.00	16.50	Direct Coupling	7/8" coax
	TN48	0.34-0.51	18.5	-	75	2.00	10.00	Helical Coupling	Type N
L	TN51	1.00-2.00	20.1	200	50	1.90	8.94	Direct Coupling	7/8" coax
	TN52	1.00-2.00	20.1	200	50	1.90	10.38	Direct Coupling	7/8" coax
	TN54	1.00-2.00	20.5	200	50	1.90	17.31	Direct Coupling	Type N
	TN55	1.25-1.55	20.1	200	50	1.90	9.56	Direct Coupling	7/8" coax
	TN57	1.28-1.35	20.5	225	50	1.90	12.56	Direct Coupling	7/8" coax
S	TN60	2.00-4.00	18.5	200	50	1.90	10.38	Direct Coupling	7/8" coax
	TN64	2.70-2.90	18.5	35	60	0.45	3.75	90°E	RG-75/U
	TN65	3.40-3.60	18.3	40	75	0.60	2.50	90°E	RG-75/U
	TN71	2.90-3.10	18.5	35	75	0.45	3.63	90°E	RG-75/U
	TN72	2.70-2.90	18.5	35	75	0.45	3.09	90°E	RG-75/U
	TN73	2.70-2.90	18.5	35	75	0.45	3.09	90°E	RG-75/U
	TN74	2.70-2.90	18.5	35	60	0.45	3.75	90°E	RG-75/U
	TN75	3.10-3.50	18.3	40	75	0.60	2.63	90°E	RG-75/U
C	TN76	5.30-6.00	18.5	60	150	0.70	2.00	90°E	RG-49/U
	TN77	5.30-6.00	13.5	60	150	0.70	3.50	90°E	RG-49/U
	TN78	5.45-5.82	18.5	60	150	0.70	2.75	90°E	RG-95/U
	TN82	5.30-6.00	13.5	60	150	0.70	3.56	90°E	RG-49/U
H	TN83	7.50-8.60	18.5	60	75	0.80	1.56	90°E	RG-51/U
	TN84	7.50-8.60	15.0	55	100	0.80	2.50	90°E	RG-51/U
X	TN94	8.90-9.10	18.5	50	60	0.95	1.63	90°E	RG-67/U
	TN95	8.50-9.60	14.5	50	100	0.95	2.50	90°E	RG-67/U
	TN97	8.50-9.60	18.5	50	75	0.95	1.63	90°E	RG-67/U
	TN101	8.50-9.60	14.5	50	100	0.95	2.25	90°E	RG-52/U
	TN124	8.20-12.4	12.5	50	50	1.00	2.50	90°E	RG-52/U
Ku(K)	TN102	15.0-16.5	18.5	60	40	1.20	1.50	90°E	RG-67/U
	TN103	12.4-18.0	18.5	140	50	2.00	7.50	0°E	RG-107/U
	TN104	15.0-16.6	12.3	95	50	1.00	1.63	90°E	RG-91/U
	TN128	12.0-14.0	13.5	50	50	1.00	2.00	90°E	RG-91/U
K(P)	TN106	18.0-26.5	18.5	175	50	1.90	6.44	0°E	RG-66/U
	TN125	22.0-23.0	12.5	65	50	1.50	2.25	90°E	RG-53/U
Ka(Q)	TN107	26.5-40.0	18.0	140	40	2.50	5.13	0°E	RG-96/U
	TN109	34.0-36.0	18.0	140	35	2.50	7.38	0°E	RG-96/U
	TN126	31.0-32.0	13.3	75	50	1.50	2.25	90°E	RG-96/U
R	TN111	50.0-75.0	18.0	230	30	2.50	4.63	0°E	RG-98/U

⁽⁵⁾ High Energy Devices can usually refurbish noise sources (depending on condition of waveguide) and install replacement tubes.

TN Series Gas Discharge Noise Source Tubes with Filamentary Cathodes Noise Tubes⁽⁵⁾

Specifications (@25°C)

Wave Guide	Part Number	Frequency Range (GHz)	Approx. ENR (dB)	Tube Drop (Vdc)	DC Anode Current (mA)	Minimum Starting Voltage Spike (kV)	Replacement Tube	Mounting	Flange Mate
WR-42	TN170	18.0-26.5	15.0	170	120	2.0	TD170	7°E	UG-595/U
WR-28	TN162	26.5-40.0	15.4	170	120	2.0	TD162	7°E	UG-599/U
WR-22	TN172	33.0-50.0	15.4	170	120	2.0	TD172	7°E	UG-599/U
WR-19	TN163	40.0-60.0	15.4	170	120	2.0	TD163	7°E	UG-385/U
WR-15	TN164	50.0-75.0	15.0	170	120	2.0	TD164	7°E	UG-385/U
WR-12	TN171	60.0-90.0	15.0	210	100	2.5	TD171	7°E	UG-385/U
WR-10	TN165	75.0-110.0	14.2	225	75	3.0	TD165	7°E	UG-385/U
WR-8	TN167	90.0-140.0	13.0	225	75	3.0	TD167	7°E	UG-385/U
WR-6	TN166A	110.0-170.0	13.0	225	50	3.0	TD166A	7°E	UG-385/U
WR-5	TN173	140.0-220.0	9.0	225	50	3.0	TD173	7°E	UG-385/U

⁽⁵⁾ High Energy Devices can usually refurbish noise sources (depending on condition of waveguide) and install replacement tubes.

Noise Source Power Supplies with Current Regulation⁽⁶⁾

Specifications (@25°C)

Part Number	For Noise Tubes ⁽⁶⁾	AC Input	DC Starting Voltage (kV)	DC Operating Current (mA)
PS237	TN162 through TN172 except TN166A	115VAC, 60Hz	5.0	150
PS238		220VAC, 50Hz	5.0	150
PS239	TN173, TN166A	115VAC, 60Hz	5.0	120
PS240		220VAC, 50Hz	5.0	75

⁽⁶⁾ These power supplies, though designed for the TN162 through TN173, are capable of operating many other noise sources made by High Energy Devices.

Contact Information:

High Energy Devices, LLC
26 Hollenberg Court
Bridgeton, MO 63044
Phone: 314.291.0030
Fax: 314.291.8184
E-mail: info@highenergydevices.com
www.highenergydevices.com

HIGH ENERGY DEVICES, LLC MAKES NO REPRESENTATIONS OR WARRANTIES WITH RESPECT TO THE ACCURACY OR COMPLETENESS OF THE CONTENTS OF THIS PUBLICATION AND RESERVES THE RIGHT TO MAKE CHANGES TO SPECIFICATIONS AND PRODUCT DESCRIPTIONS AT ANY TIME WITHOUT NOTICE. NEITHER CIRCUIT PATENT LICENSES NOR INDEMNITY ARE EXPRESSED OR IMPLIED. EXCEPT AS SET FORTH IN HIGH ENERGY DEVICES' STANDARD TERMS AND CONDITIONS OF SALE, HIGH ENERGY DEVICES, LLC ASSUMES NO LIABILITY WHATSOEVER, AND DISCLAIMS ANY EXPRESS OR IMPLIED WARRANTY, RELATING TO ITS PRODUCTS INCLUDING, BUT NOT LIMITED TO, THE IMPLIED WARRANTY OF MERCHANTABILITY, FITNESS FOR A PARTICULAR PURPOSE, OR INFRINGEMENT OF ANY INTELLECTUAL PROPERTY RIGHT.

THE PRODUCTS DESCRIBED IN THIS DOCUMENT ARE NOT DESIGNED, INTENDED, AUTHORIZED OR WARRANTED FOR USE AS COMPONENTS IN SYSTEMS INTENDED FOR SURGICAL IMPLANT INTO THE BODY, OR IN OTHER APPLICATIONS INTENDED TO SUPPORT OR SUSTAIN LIFE, OR WHERE MALFUNCTION OF HIGH ENERGY DEVICES' PRODUCT MAY RESULT IN DIRECT PHYSICAL HARM, INJURY, OR DEATH TO A PERSON OR SEVERE PROPERTY OR ENVIRONMENTAL DAMAGE. HIGH ENERGY DEVICES, LLC RESERVES THE RIGHT TO DISCONTINUE OR MAKE CHANGES TO ITS PRODUCTS AT ANY TIME WITHOUT NOTICE.

Specification: TD/TN Series
©Copyright 2002, High Energy Devices, LLC
All rights reserved. Printed in USA
March 2008.